







User's and Installation Guide

SPRAYMAT II

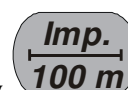

January 2004

Contents

1	System description	4
2	Safety instructions	5
2.1	Disclaimer	5
2.2	Safety measures	5
2.3	Safety notice for the subsequent installation of electrical and/or electronic components	7
3	EC declaration of conformity	8
4	Installation instructions	9
4.1	Computer	9
4.2	Sensors - generally	9
4.3	Sensor X (distance impulses).....	9
4.3.1	Possible operating modes.....	9
4.3.2	Sensor X – Four-wheel drive tractors/MB-Trac	10
4.3.3	Sensor X – tractors without four-wheel drive and other machines.....	10
4.3.4	Sensor X – speed adapter (Unimog)	10
4.3.5	Sensor X with forward/reverse evaluation for combine harvesters	10
4.3.6	Connection to the tractor signal socket.....	11
4.4	Sensor Y – working position	11
4.5	RPM monitoring	13
4.6	Connection to field sprayers	14
4.6.1	Connection to a mechanical manifold	15
4.6.2	Sensor Y (working position).....	15
4.6.3	Connection to an electrical manifold.....	16
4.7	Connection to manure carts.....	16
4.8	Cable assembly	17
5	Operating instructions	18
5.1	Initial operation.....	18
5.2	Description of the input keys	18
5.2.1	"Working width" key 	18
5.2.2	"Impulses/100m" key 	19
5.2.3	"Impulses / litre" key 	19
5.2.4	"Number of boom sections" key; "Boom sections +/-"   	20
5.2.5	Programming the shaft speed monitor 	20
5.3	Description of the function keys	21
5.3.1	Device on/off 	21

5.3.2 "Start function"		21
5.3.3 "Time" key		21
5.3.4 "Area" key"		21
5.3.5 "Total area" key		21
5.3.6 "Current area output" key		22
5.3.7 "Litre" key		22
5.3.8 "Total litres" key		22
5.3.9 "Litre/min" key		22
5.4 Operating procedure		22
5.5 Converting the board computer		22
6 Maintenance		22
6.1 Computer		23
6.2 Flow meter		23
7 Error recovery		24
7.1 The device does not switch on		24
7.2 Area is not being measured		24
7.3 Speed is not displayed		24
7.4 Spread rate is not displayed		24
7.5 The rpm alarm goes off although speed within limit		24
8 Appendix		24
8.1 Technical data		24



1 System description

You have acquired a device which can be installed as a monitoring and display instrument on various field sprayers. In addition it can be installed as a measuring and control instrument on practically all self-driven agricultural machinery.

It consists of the board computer and a set of cables with sensors for recording impulses.

It has been constructed taking the harsh conditions under which it used into account. As a result the front plate consists of an extremely robust but at the same time very clear tactile keyboard, allowing quick and simple operation of the device.

All pre-set and recorded values remain stored in the device for many years, even when the board mains are switched off.

They are available as soon as the device is switched on again.

The device has following functions:

- Automatic display of the speed and the current spread rate
- Calculation of the area and the total area e.g. per season
- Calculation of the spread rate and the total spread rate e.g. per season
- Calculation of the working time
- Display of the current area performance
- Display of the current spread rate (l/min)
- Rpm control
- Boom section adjustment

2 Safety instructions

2.1 Disclaimer

The **SPRAYMAT II** is specified exclusively for agricultural use. The manufacturer takes no responsibility for any installation or application outwith this area.

The manufacturer does not accept liability for damage to persons or property resulting from unspecified use. In such cases all risks are the responsibility of the user.

Specified implementation also includes adhering to the operation and maintenance requirements stipulated by the manufacturer.

Relevant accident prevention regulations as well as other generally recognised safety, industrial, health and road traffic rules are to be adhered to. In addition the manufacturer accepts no liability in cases where arbitrary modifications have been made to the device.

2.2 Safety measures

Warning!



Always pay attention to this symbol for references to important safety precautions.











It means attention! Become alert!

It is a question of your safety.



Read the user's guide before using **SPRAYMAT II** for the first time.

Observe the following recommended precautions and safety instructions:

-  Before using the **SPRAYMAT II** read and understand this guide. It is of equal importance that others operating this device also read and understand the manual.
-  During maintenance or when using a battery charger, switch off the power supply.
-  Never service or repair the device while the job computer is switched on.
-  Before welding on the tractor or on an attached machine, interrupt the power supply to the **SPRAYMAT II**.
-  Only use clear water or a damp cloth with a little glass cleaning agent to clean the **SPRAYMAT II**.
-  Operate the keys with your finger tips but avoid using fingernails.
-  Should any part of this guide remain incomprehensible after reading, contact the dealer or Mueller-Elektronik Service for further clarification before using the **SPRAYMAT II**.
-  Read carefully all safety instructions in the manual.
-  Learn how to operate the **SPRAYMAT II** correctly. Nobody is to operate the machine without exact instructions.
-  Keep the **SPRAYMAT II** and the spare parts in good condition. Unspecified alterations can impair the function and/or safety and affect the life span of the machine.

2.3 Safety notice for the subsequent installation of electrical and/or electronic components

Present-day agricultural machines are equipped with electronic components and devices, whose function can be affected by electromagnetic emission from other devices. These influences can lead to endangerment for individuals when the following safety measures are not adhered to.

When subsequently installing electrical and electronic devices and/or components in a machine with a connection to the electrical system, the user must take sole responsibility for testing the installation for interference of the vehicle electronics or other components. This applies in particular to the electronic controls of:

- EHR,
- front lifting gear,
- power take-off shafts,
- motor and
- gears.

Above all it must be ensured that all subsequently installed electrical and electronic components comply with the current version of the EMC directive 89/336/EWG and carry the CE symbol.

In addition the following requirements must be fulfilled when upgrading with mobile communication systems (e.g. radio, telephone):

- Only approved devices complying to national regulations (e.g. BZT approval in Germany) are to be installed;
- The device must be securely installed;
- The use of portable or mobile devices inside the vehicle is permissible only via a connection to a permanently installed outside antenna;
- The transmitting unit is to be installed in a position away from the vehicle electronics;
- An antenna should only be installed professionally ensuring that there is a good earth connection between the antenna and the vehicle chassis.

Please refer to the manufacturer's installation instructions for cabling and installation as well as the maximum current consumption.

3 EC declaration of conformity

Unser Produkt

SPRAYMAT II

ist in Übereinstimmung mit folgenden nationalen und harmonisierten Normen im Sinne der EMV-Richtlinie 89/336/EWG hergestellt.

Angewandte Norm: EN ISO 14982

Salzkotten, 22.01.2004
(Ort und Datum)

H. Müller, Geschäftsführer

R. Buschmeier, Geschäftsführer

Datei: KE_EG_SPRAYMAT_II.doc [1 / 22.01.04]

4 Installation instructions

4.1 Computer

Operating voltage is **12 V** and must be taken directly from the battery or from the 12-volt starter. Care should be taken when laying the **battery cable** and it should be shortened if necessary. The crimp ring terminal for the ground line (blue) and the end sleeve for strands for the + line (brown) should be fitted using suitable pliers. The end sleeve for strands for the + line are in the connection clamp of the fuse holder.

brown = + 12 volts
blue = ground



Attention !!!

The voltage supply must be taken directly from the battery or from the 12-v starter. Attention must be paid to polarity.

4.2 Sensors - generally

The sensor X with one sensing element and the rpm sensors have an electronic switch (Hall element).

With these sensors it is possible to record impulses e.g. from a cardan shaft. They should be mounted, as illustrated in diagram A, at a distance of 5-10mm.

Diagram A

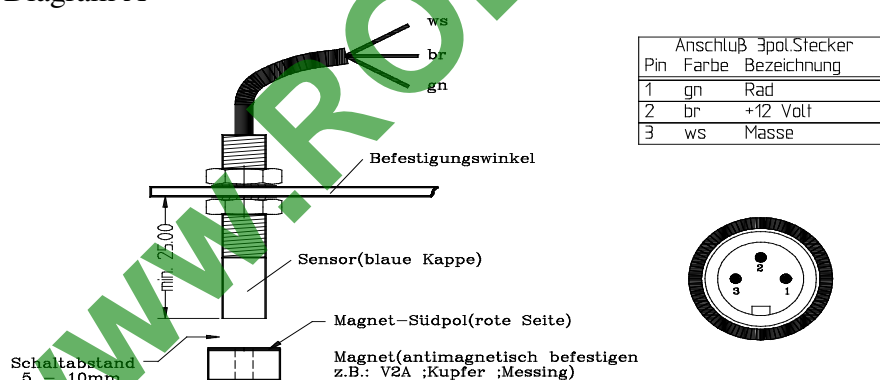

4.3 Sensor X (distance impulses)

4.3.1 Possible operating modes

The sensor X is for the evaluation of the course and the speed. Depending on the purpose of the device, various sensors can be used, as described below.

- Sensor X (1 sensing device)

Impulse recording is taken at a non-driven wheel or at the cardan shaft on four-wheel drive tractors (diagram A; 5-10mm distance).

- Sensor X with forwards/backwards evaluation (2 sensing devices)
This sensor is intended for use with combine harvesters, in order to achieve accurate area calculation, even when the mowing attachment in working position has to be towed free. (Reversing). (4.3.5).
- Connection to the tractor signal socket (ISO 11786)
The device can be connected with a special adapter if this socket exists.

4.3.2 Sensor X – Four-wheel drive tractors/MB-Trac

Mounting on MB-Trac and other four-wheel drive tractors (diagram A). The distance impulses are taken from the cardan shaft. Mounting is carried out as follows:

Rivet the magnets to a hose clamp using a copper rivet. Then put this round the cardan shaft and tighten.

By means of the bracket provided, mount the sensor X to a static part of the vehicle opposite the magnets. The sensor must point in the direction of the magnets. The distance should be 5-10mm. The ring on the left-hand side of the display must flash during the journey.

4.3.3 Sensor X – tractors without four-wheel drive and other machines

The magnet is installed in the wheel shell of the tractor's front wheel. If the wheel's circumference is more than 2 m, 2 magnets have to be distributed evenly over the circumference. Mount the sensor to a static part of the vehicle using the bracket provided, so that the end of the sensors is pointing towards the magnets (diagram A). The distance should be 5-10mm. The ring on the left-hand side of the display must flash during the journey

4.3.4 Sensor X – speed adapter (Unimog)

Dismantle the speedometer drive from the gearbox and screw on the speed adapter in its place. Apply multi-purpose grease to the shaft with the magnets and insert it with the yoke pointing downwards.

Screw the speedometer drive on to the adapter. The ring on the left-hand side of the display must flash during the journey.

4.3.5 Sensor X with forward/reverse evaluation for combine harvesters

This sensor has 2 sensing devices. This allows the device to determine if the combine harvester is moving forwards or in reverse. Important is that, when driving forwards, the magnet at first draws closer to the magnet switch with the long connecting cable.

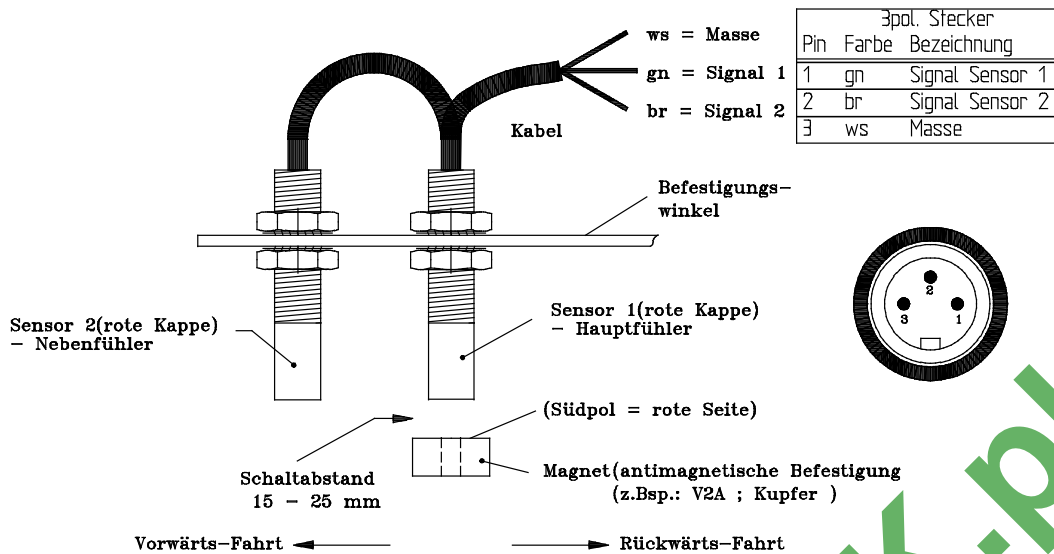

The sensor is to be mounted using the flat profile supplied. Depending on how it is to be mounted, it has to be bored or bent.

Bore a 5mm hole or M5 screw thread in the wheel shell opposite the sensor. Screw the magnet directly in to the wheel shell using the V 4A screw. The distance of approx. 15mm - 25mm between the magnet and the sensor is obtained by the screw connection at the sensors.

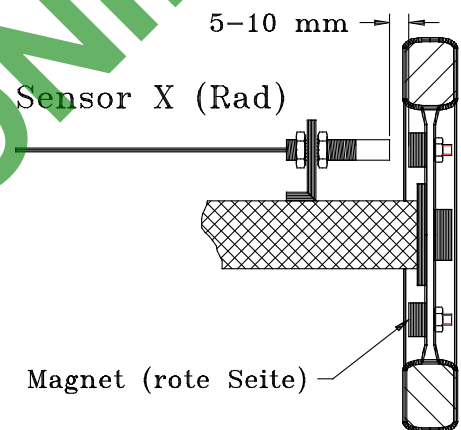

4.3.6 Connection to the tractor signal socket

Insert the correct adapter for the tractor into the signal socket and the computer's input X.

4.4 Sensor Y – working position

Mount the magnet on to a machine part using the V4A screws in such a way that its position changes from transport into working position. Opposite it, mount the sensor on to a static part of the vehicle. In order to close the contacts, the magnet in working position must be placed in front of the sensor. In this way the impulses from sensor X to the computer take effect. If the machine is in working position, the arrow on the left-hand side of the display must be visible.

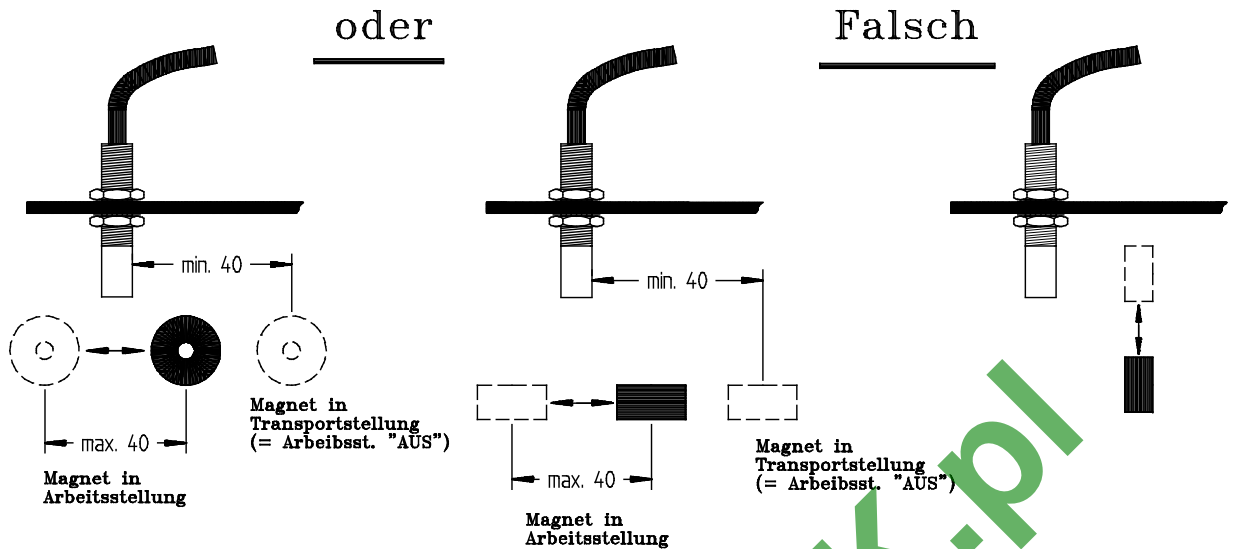

If the part of the machine being monitored moves more than 4 cm in front of the magnet switch in working position, a 2nd magnet is to be mounted in the magnet's direction of movement.

When the machine is brought to transport position, the magnet must remove itself from the sensor at a distance of at least 3 cm. The contacts are then opened and the impulses from sensor X to the computer are ineffective.

Assembly - examples:

a) Combine harvester

Bring the cutter bar into the working position "shortest length of stubble". Install the sensor with the enclosed flat profile in the proximity of the slope conveyor. Screw the magnet to the slope conveyor opposite the sensor (bore a M5 thread). The cutter bar is brought into the position "longest stubble length". Check the magnet sensor position as described in diagram 2. If the magnet has moved too far from the sensor, install the 2nd magnet provided opposite the sensor. Note that the maximum distance between the magnets one below the other should not exceed 7 cm. The distance of 15-25mm between the magnet and the sensor is set by the screw connection. If the cutter bar is in transport position, the distance between the sensor and the nearest magnet should be at least 3 cm.

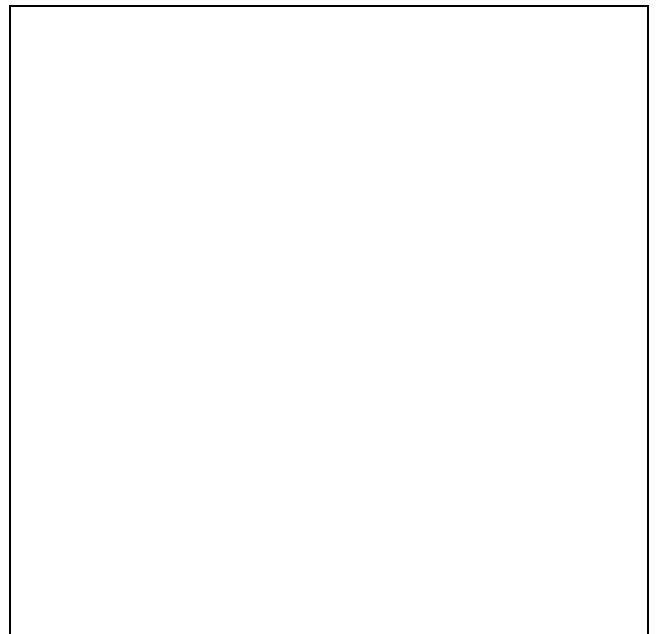

b) Tractor hydraulics

The tractor hydraulics are brought into working position by the machine attached. Bore the magnet to the lifting arm (bore a M5 thread).

Mount the sensor to a static part of the vehicle opposite the magnets using the flat profile provided. The distance magnet - sensor (15-25mm) is set at the sensor by the screw connection. If, during operation, the lifting arm moves so much that the magnet leaves the sensor's active area, mount the 2nd magnet provided next to the existing one in the direction of movement (if necessary secure a small flat profile to the lifting arm).

Note that the maximum distance between the magnets one above the other should not exceed 7 cm. In transport position, the distance between the sensor and the nearest magnet should be at least 3 cm.

c) Other machines

e.g. Beet harvesters can be controlled in the same way. The instructions in chapters 4.2 and 4.4 should be adhered to.

- d) If a machine is brought into working position by a lever (e.g. plant protection sprayer, manure sprayer) mounting can be carried out as follows:

Screw the magnet to the lever. Mount the sensor in such a way that in working position, it is opposite the magnet.

The Sensor Y is not required with machines which are always in working position during operation (manure sprayer). A Y sensor is also superfluous e.g. on seed machines when the sensor X (distance) is at the wheel of the seed machine. Idle runs on the headland are not evaluated as the machine is lifted and the wheel is not turning.

In this case a short circuit plug should be ordered instead of the sensor Y (price advantage).

4.5 RPM monitoring

One RPM control is possible. This sensor has an electronic component which reacts to a magnetic field and sends an impulse to the computer. 2 magnets must be attached to the monitoring shaft. The magnets must move past the end of the sensor at a distance of 5-10mm:



RICHTIG

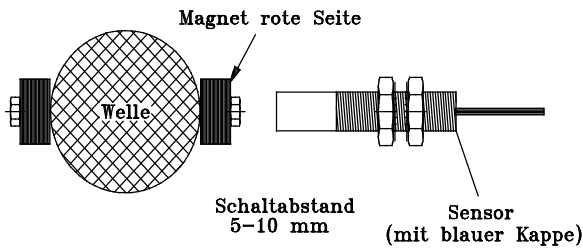

FALSCH

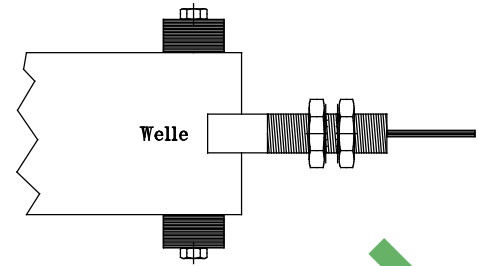

Magnete antimagnetisch befestigen

Please note that the painted end of the magnet must point to the sensor. The sensor can only recognize the south pole of the magnet. If the magnets are mounted to accessible but unprotected shafts, protection must be provided in accordance with the regulations of the Trade Association.

4.6 Connection to field sprayers

Two mounting units are available. Connection to an electrical manifold or to a mechanical manifold. In both cases a balanced pressure manifold is required. The flow meter measures the amount spread over the whole working width of the field sprayer. If one or more boom sections are switched off, the computer also records the amount which flows into the tank via the balanced pressure manifold. The "boom section minus" key should be pressed once for each switched-off boom section. The switched-off boom sections are taken into account by the area and quantity evaluation.

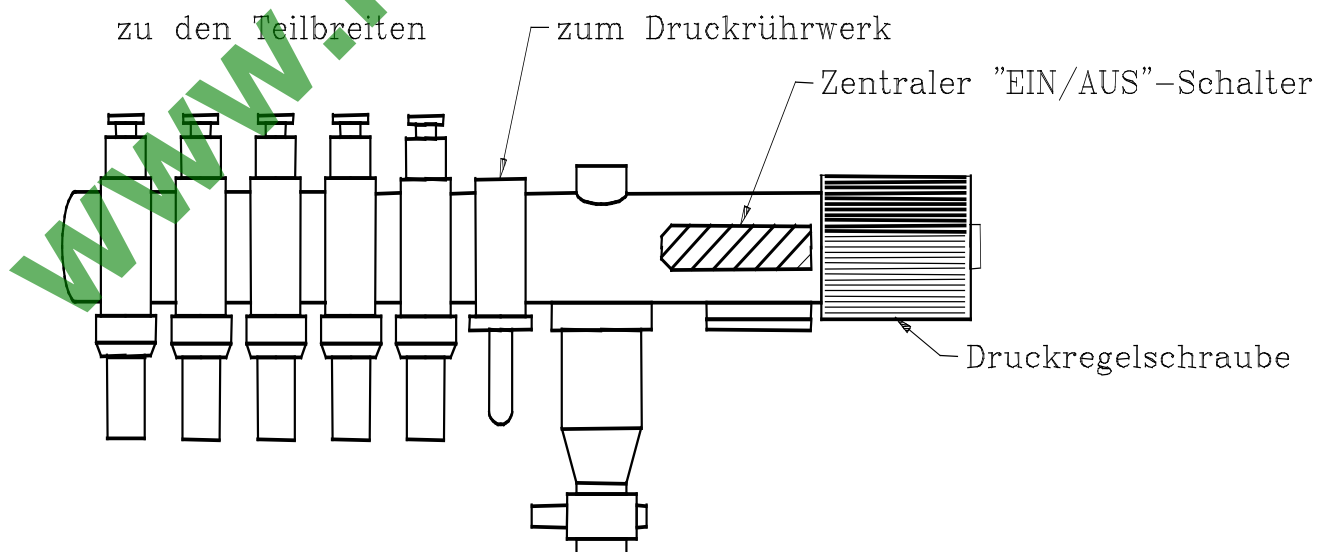

Manifold without flow meter

The flow meter is installed between the pressure control valve and the boom section manifold.

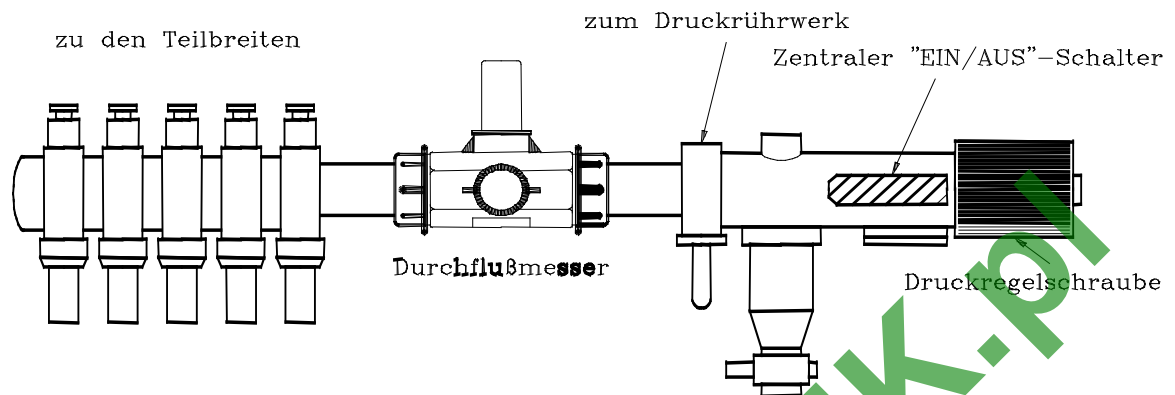

Manifold with installed flow meter

In order to separate the manifold, the field sprayer manufacturers offer standard mounting units, enabling simple and fast mounting.

4.6.1 Connection to a mechanical manifold

Independent of the type of manifold following points should be noted:

- The flow meter must be mounted between the pressure control part and the boom section part. Only the quantity spread via the spray bar or which flows back into the tank via the balanced pressure manifold should be measured.
- Note the direction of flow (arrow on the flow meter)
- The working position is taken from the on/off lever.

4.6.2 Sensor Y (working position)

Mount the magnet to the manifold's switch handle using the V 4A screws provided.

Mount the sensor Y opposite the magnets. The distance should be 10-20mm.

The transmitter must point towards the painted side of the magnet.

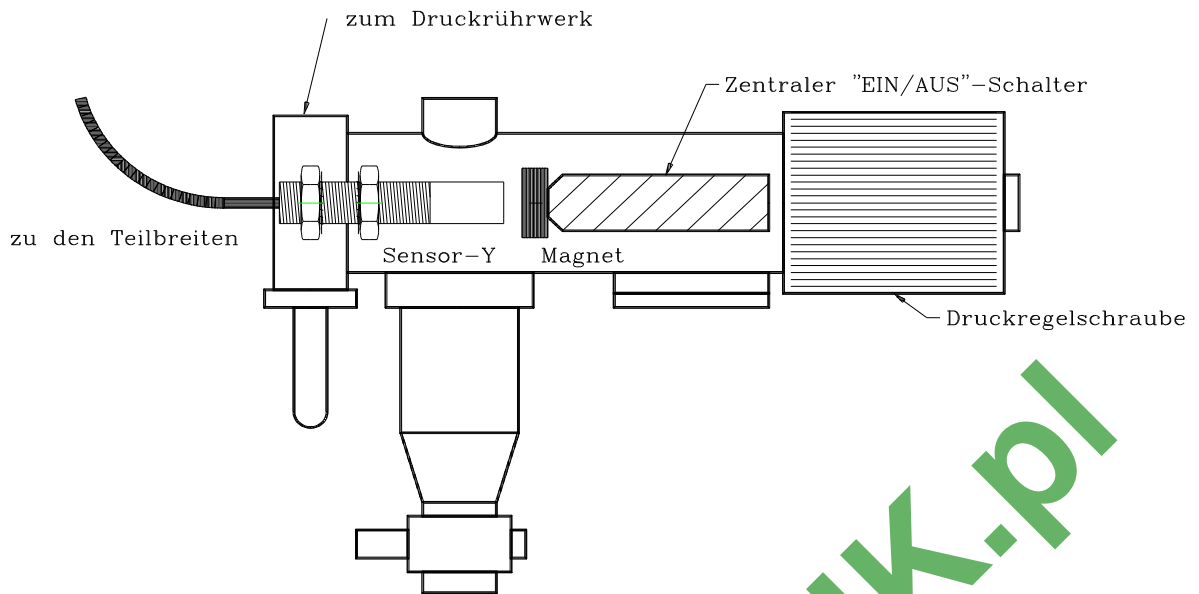

4.6.3 Connection to an electrical manifold

Independent of the type of manifold following points should be noted:

- The flow meter must be mounted between the pressure control part and the boom section part. Only the quantity spread via the spray bar or which flows back into the tank via the balanced pressure manifold should be measured.
- Note the direction of flow (arrow on the flow meter).
- The working position is taken from the on/off switch on the switch box.

4.7 Connection to manure carts

The flow meter is to be positioned in the tube to the distributor system in such a way that only the quantity which is actually spread flows through the flow meter. In front of the flow meter there must be a straight piece of tubing with a length of 10 x nominal width (10 x 100 mm = 1 m). Behind the flow meter a straight piece of tubing with a length of 3 x nominal width is required.

The tube must have the same nominal width as the flow meter. Mount the flow meter joint-free between the flanges so that no liquid turbulence can develop. The direction of the flow, marked with an arrow on the flow meter, must be adhered to.

The flow meter can be mounted in a horizontal or perpendicular positioned tube. Preference should be given to the perpendicular position, as air locks in the liquid have a negative effect on measurement accuracy.

Grounding the flow meter.

Connect the ground wire from the casing carefully to the adjacent flange

Connection in the distributor.

a) Flow meter

Connect the flow meter cable in the distributor at the clamps marked "flow meter".

wire 4 = operation ground
wire 3 = + 12 volts
wire 2 = signal
wire 1 = ground

b) Inductive pump rotation sensor (only with pump tank trailer)

brown = br
black = sw
blue = bl

The lid of the flow meter must not be opened. In the case of violation the guarantee is no longer binding.

In addition the enclosed manufacturer's operating instructions should be adhered to.

4.8 Cable assembly

Lay the cable to the computer very carefully using the installation material provided. Bore a 3mm hole for the sheet metal screws which secure the cable clamps. Use cable binders if the cable can be laid alongside an existing cable or wire.

Secure the cable directly behind the sensors so that any possible tension in the cable does not affect the interior of the sensors. Attention has to be paid to ensure that the function of the machine is not in any way impaired.

WWW.ROTHRONIK.PL

5 Operating instructions

5.1 Initial operation

The device carries out a self-test when switched on. When completed the function last used before switch-off is automatically selected.

In the case of an electrical fault the device displays:

HALP 00 or HALP 88.



In this case return the device for repair.

5.2 Description of the input keys

The keyboard has two colours:

white keys = function keys (display the recorded data)

grey keys = input keys (enter the machine data)

When the  or  key is first pressed the display moves one position in the required direction.



Each time the key is pressed again the display moves continuously until pressure from the key is lifted.

The board computer requires the following information before operation can commence: impulses/100m, working width, number of boom sections and the nominal rpm.

5.2.1 "Working width" key



This key is used to enter the current working width:

- Press the "working width" key
- Enter the value using the keys  and 
- Press 





Finally the value entered should be controlled once more by pressing .

5.2.2 "Impulses/100m" key



With this key the number of impulses recorded to the computer by the sensor X during a test journey of 100m is entered.

There are two possibilities to enter the data:

1. The impulses/100m value is known

- Press 
- Enter the value using the keys  and 
- Press 

2. The impulses/100m value is not known





- Measure out and mark a distance of 100m on the field
- Bring the vehicle to the start position
- Press  and  simultaneously.
- Travel a distance of 100m. The computer adds up the impulses during the journey.
- Press 

5.2.3 "Impulses / litre" key





This key is used to enter the number of impulses which the flow meter per litre records to the computer.

There are two possibilities to enter the data:

1. The impulses/litre value is known:

- Press 
- Enter the value using the keys  and 
- Press 



2. The impulses / litre value is not known or has to be checked:





- Fill the tank with water and determine the amount.
- Press  and  simultaneously.
- Switch on the field sprayer while static and spray a few hundred litres (the computer will now count the impulses from the flow meter).
- Determine the spread rate (reweigh).
- Enter this value using the keys  and .
- Press 

The computer has now calculated the value "Impulses/ litre."

5.2.4 "Number of boom sections" key; "Boom sections +/-"





1 to 12 boom sections can be entered. For the combine harvester it is advisable to enter 4 boom sections. For a 6-row crop chopper enter 6 boom sections. Adjustment to the current working width can be carried out using the keys  and . At the end of the field when the working position is switched off, the computer switches automatically to the full working width.

- Press 
- Enter the value using the keys  and 
- Press 

5.2.5 Programming the shaft speed monitor





Before the season begins the nominal speed of the shaft to be monitored must be communicated to the Spraymat. The entry should be carried out as follows:

- Start up the machine (normal load)
- Press  (e.g. pump) (current speed in rpm will be displayed)
- Press 

The value displayed at this moment in time is stored as the nominal speed.

If e.g. the board computer is to be transferred to another machine and monitoring has to be switched off, the following input is required:



- Press  drücken (display 0)
- Press 
- RPM monitoring is so switched off

After the values described in paragraph 5.2.1 - 5.2.4 are entered, the board computer is ready for operation.

5.3 Description of the function keys





5.3.1 Device on/off

The device is switched on and off by pressing . Should the voltage supply drop to below 9 volts e.g. when starting the tractor, the computer switches off automatically. It can be switched on again by pressing the  key.



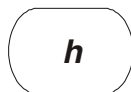

5.3.2 "Start function"

The start function is activated by pressing the keys  and  simultaneously. That means that the memory for the area, time, distance and events counter is set to 0. The time is restarted automatically by pressing this key. This function is to be carried out at the beginning of each operation.



5.3.3 "Time" key

The operating time since carrying out the "start function" (see 5.3.2) is displayed by pressing this key. If the tractor is switched off and the computer is voltage-free, the time data input is stopped. It restarts once the device is switched on again. The clock can also be stopped during operation. After the  key has been pressed, it can be pressed once again to stop the clock. To restart it press  yet again.



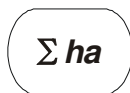

5.3.4 Area" key"

The area covered since carrying out the "start function" 5.3.2 is displayed here. Measurement is interrupted as soon as the working speed is no longer recorded to the computer from the sensor Y.



5.3.5 "Total area" key

With this key the total area for a whole season is determined. The memory is set to 0 at the beginning of the season by pressing the keys  and  simultaneously.

ha/h

5.3.6 "Current area output" key

With this key the current area output is displayed in ha/h.



l

5.3.7 "Litre" key

The number of litres spread since carrying out the "start function" (see 5.3.2) are displayed here.

Σ l

5.3.8 "Total litres" key

With this key the total amount spread during the season is displayed. The memory is set to 0 at the beginning of the season by pressing the keys  and  simultaneously.

l/min.

5.3.9 "Litre/min" key

The current spread rate is displayed when this key is pressed.





5.4 Operating procedure

Once the machine data have been entered (see 5.2), only the start function has to be carried out before operation can begin (see 5.3.2). During operation any value required can be displayed. After 10 secs the speed and spread rate (l/ha) are displayed once again. Once operation has ended all values can be called up and noted.

5.5 Converting the board computer

When transferring the computer from one machine to another, remove the sensor's multipole connectors. Then loosen the cable for the 12V voltage supply and remove the device from the console.

Carry out this procedure in reverse order when installing the device. The device must then be adapted to the new machine.

This involves the working width , the impulses/100m , and if required, the number of boom sections  and the shaft speed monitor  (see initial operation). The total area should also be noted and deleted.

6 Maintenance

6.1 Computer

The computer is maintenance-free. It has an internal safety fuse. During the winter it should be stored at room temperature and protected from dampness.

6.2 Flow meter

Rinse the flow meter with water each time after use. At the end of the season check the run of the impeller wheel and replace if necessary.

The accuracy of the flow meter's display should be checked before initial operation and regularly during the season (see 5.2.3).

WWW.ROLTRONIK.PL

7 Error recovery

Error	Cause	Measures
7.1 The device does not switch on	Polarity reversal of the voltage supply	Check polarity
	Voltage supply interrupted	Check battery connection cable; control battery clamps and fuse.
7.2 Area is not being measured	"Working width" or Imp./100m" have not been entered	Enter values (see 5.2.1 and 5.2.2)
	No impulses from the transmitter for the distance. The ring in the display is not flashing.	Check sensor X. check the cable to the sensor for damage, replace sensor if necessary.
	Sensor X - 2 sensing elements During forward journey the area is measured backwards and in reverse forward measurement	Swap the sensors at the wheel (see 4.3.5)
7.3 Speed is not displayed	Impulses are not reaching the computer	Correct distance of the magnet to the sensor to 5-10mm
		Check cable for damage and if necessary replace
7.4 Spread rate is not displayed	Impulses are not reaching the computer from the flow meter	Check the flow meter (Turbine)
		Check the cable for damage and replace if necessary.
7.5 The rpm alarm goes off although speed within limit	The set nominal speed given is too high	Repeat programming with a lower nominal speed (see 5.2.3)

Tab. 7-1 Error recovery

8 Appendix

8.1 Technical data

Operating voltage:	10.5 V to 16 V
Operating temperature:	-20 °C to 70 °C
Storage temperature:	-40 °C to 85 °C
Safety class:	IP 54
Weight:	0,7 kg
Measurements (L x B x D):	170x170x100 mm

Tab. 8-1 Technical data